

English abstract of JP 03-056254

PROBLEM TO BE SOLVED: To provide an opening section device capable of positioning the ends of a sliding door on proper positions to air-tight members when the sliding door is fully shut.

SOLUTION: Rebates 20 and 22 consisting of recess sections for accepting the ends of sliding door are formed in both right and left stiles 4 and 5, at the same time, the air-tight members 25 and 26 are provided to stage sections 23b and 24b of the rebates near to the ends of the sliding door in the case it is fully shut, spacer members 40 and 44 for filling in an unnecessary space of the rebate 22 formed in a joint part between the head 2 and the sill 3 are mounted on at least one end section of the stiles, at the same time, a taking in member 30 of a sliding door guide rail 13 is provided on the ends of the sliding door, rail extended members 42 and 46 extended from the sliding door guide rail 13 are integrally formed in the spacer member 40, and attractable faces 42a and 46a for positioning the ends of the sliding door on the proper positions to the air-tight members 25 and 26 are formed in the rail extended member 42 while coming into contact with the inside of the taking in member 30.

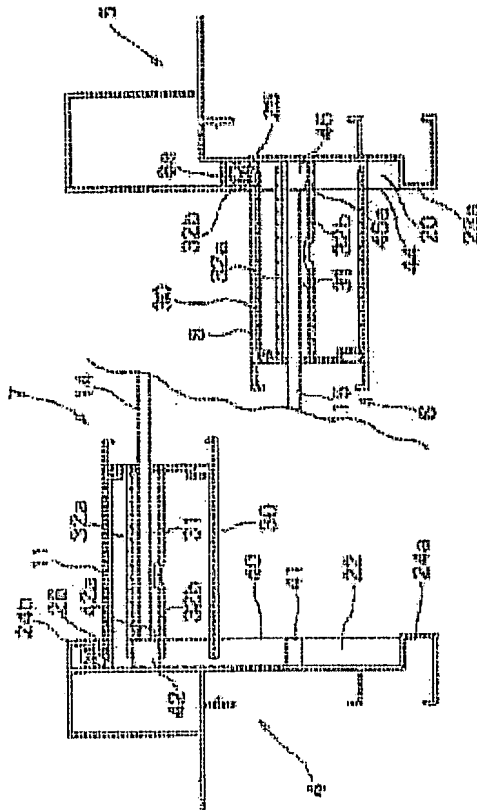

Machine translation JP2003056254

(19)**Publication country**Japan Patent Office (JP)
 (12)**Kind of official gazette**Publication of patent applications (A)
 (11)**Publication No.**JP,2003-56254,A (P2003-56254A)
 (43)**Date of Publication**Heisei 15(2003) February 26 (2003.2.26)
 (54)**Title of the Invention**Opening device
 (51)**The 7th edition of International Patent Classification**

E06B 3/46

7/22

FI

E06B 3/46

7/22 Z

Request for ExaminationUnrequested**The number of claims** 1**Mode of Application**OL**Number of Pages**6(21)**Application number**Application for patent 2001-244149 (P2001-244149)(22)**Filing date**Heisei 13(2001) August 10 (2001.8.10)(71)**Applicant****Identification Number**302045705**Name**TOSTEM CORP.**Address**2-1-1, Ojima, Koto-ku, Tokyo(72)**Inventor(s)****Name**Field Above ****Address**2-1-1, Ojima, Koto-ku, Tokyo Inside of TOSTEM CORP.(74)**Attorney****Identification Number**100077687**Patent Attorney****Name**Gotoda Chapter**Theme code (reference)**

2E014

2E036

F-term (reference)

2E014 AA01 FA06 FB01 FB06 FB11

2E036 AA02 BA01 CA01 DA02 EB07 GA02 HB05 HC03 HC07

Abstract:

PROBLEM TO BE SOLVED: To provide an opening section device capable of positioning the ends of a sliding door on proper positions to air-tight members when the sliding door is fully shut.

SOLUTION: Rebates 20 and 22 consisting of recess sections for accepting the ends of sliding door are formed in both right and left stiles 4 and 5, at the same time, the air-tight members 25 and 26 are provided to stage sections 23b and 24b of the rebates near to the ends of the sliding door in the case it is fully shut, spacer members 40 and 44 for filling in an unnecessary space of the rebate 22 formed in a joint part between the head 2 and the sill 3 are mounted on at least one end section of the stiles, at the same time, a taking in member 30 of a sliding door guide rail 13 is provided on the ends of the sliding door, rail extended members 42 and 46 extended from the sliding door guide rail 13 are integrally formed in the spacer member 40, and attractable faces 42a and 46a for positioning the ends of the sliding door on the proper positions to the air-tight members 25 and 26 are formed in the rail extended member 42 while

coming into contact with the inside of the taking in member 30.

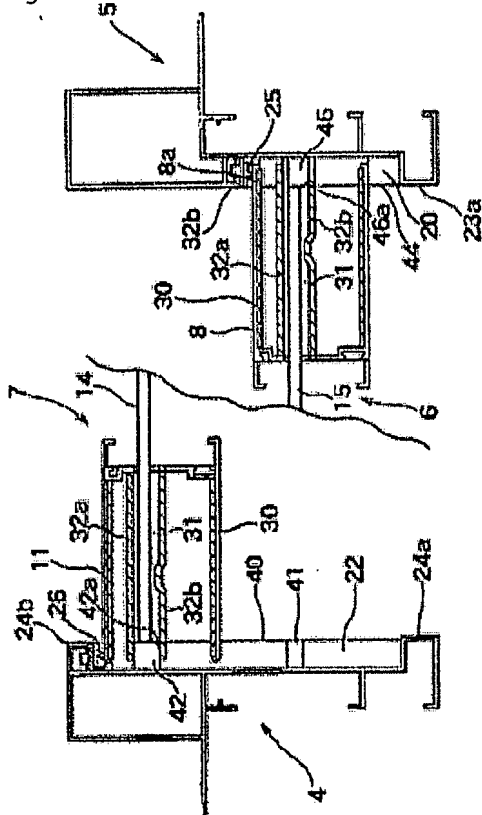

JPO Machine translation abstract:

(57) Abstract

SUBJECT When making a shoji into full close, the door end of a shoji is positioned in a suitable position to an airtight material.

Means for Solution While forming the rebates 20 and 22 which become the door posts 4 and 5 on either side from a crevice in which a door end of a shoji is accepted, respectively, The airtight materials 25 and 26 are formed in the steps 23b and 24b of a rebate close to a door end of a shoji at the time of full close, the spacing members 40 and 44 for filling an unnecessary space of the rebate 22 formed in a joining section with the vertical frames 2 and 3 are attached to at least one end of said door post -- both, The swallowing member 30 of the shoji guiding rail 13 is formed in the door-end side of said shoji, The rail extension members 42 and 46 extended from the shoji guiding rail 13 are formed in the spacing member 40 in one, a door end of a shoji is positioned in a proper position to the airtight members 25 and 26, understanding to this rail extension member 42, and touching an inner surface of the member 30 -- it draws near and the fields 42a and 46a are formed.

Claim(s)

Claim 1 While forming a rebate which consists of a crevice characterized by comprising the following which is an opening device and accepts a door end of a shoji in a door post of said right and left, respectively, An airtight material is formed in a door end of a shoji at the time of full close, a step of an approaching rebate, or said door end, a spacing member for filling an unnecessary space of a rebate formed in a joining section with said vertical frame is attached to at least one end of said door post -- both, Provide a swallowing part of a shoji guiding rail in the door-end side of said shoji, and to said spacing member. An opening device characterized by a thing which position a door end of a shoji in a proper position to said airtight member while forming in one a rail extension member extended from a shoji guiding rail of said cope box or a drag flask and touching said rail extension member with an inner surface of said swallowing part, and for which it drew near and a part was formed.

A frame formed with a four-directions frame.

A shoji of two right and left opened and closed by lengthen difference within said frame.

Detailed Description of the Invention**0001**

Field of the InventionThis invention relates to the opening device made as **position / the door end of a sliding door / by the proper position in a rebate** , when the opening device which has a sliding door attached to the opening of houses, such as the door, is started and a sliding door is shut especially.

0002

Description of the Prior ArtConventionally, this kind of opening device is widely used as an entrance sliding door in a common house. A sliding door consists of a shoji (door object) of two sheets opened and closed by lengthen difference, and a window screen is attached further in many cases.

0003In such a sliding door, the guide rail which shows a cope box or a drag flask to the opening and closing movement of a shoji can be provided, and can be, and it can open now to a shoji and close smoothly by making it fixed backlash and deflection arise.

0004The crevice called the rebate which accepts the door end of a shoji is formed in the door post.

If a shoji is shut, the door end will go into a rebate, it will hit with an airtight material, and a crevice will arise.

0005

Problem(s) to be Solved by the InventionHowever, if it was in the drag flask, since it did not show around with a guide rail, when the door end of a shoji had shut the shoji thoroughly, the door end swayed and it had the fault that did not enter into a rebate or a crevice was made without a door end and an airtight material hitting properly.

0006Then, there is the purpose of this invention in providing the opening device which can position the door end of a shoji in a suitable position to an airtight material, when canceling the problem which said conventional technology has and making a shoji into full close.

0007

Means for Solving the ProblemA frame in which this invention was formed with a four-directions frame in order to attain the aforementioned purpose, While forming a rebate which consists of a crevice which is an opening device which has a shoji of two right and left opened and closed by lengthen difference within said frame, and accepts a door end of a shoji in a door post of said right and left, respectively, An airtight material is formed in a door end of a shoji at the time of full close, a step of an approaching rebate, or said door end, a spacing member for filling an unnecessary space of a rebate formed in a joining section with said vertical frame is attached to at least one end of said door post -- both, Provide a swallowing part of a shoji guiding rail in the door-end side of said shoji, and to said spacing member. It is characterized by a thing which position a door end of a shoji in a proper position to said airtight member and for which it drew near and a part was formed, forming in one a rail extension member extended from a shoji guiding rail of said cope box or a drag flask, and touching said rail extension member with an inner surface of said swallowing part.

0008

Embodiment of the InventionHereafter, one embodiment of the opening device by this invention is described, referring to attached Drawings. Drawing 1 is a front view showing the embodiment which applied this invention to the entrance sliding door of the house. Kamoi 2 which is a cope box, the threshold 3 which is drag flasks, and the frame which carried out the four-quarters group of the door posts 4 and 5 on either side are attached to the opening of the door, and it is built so that the shojis 6 and 7 of two sheets may be opened and closed by this frame at a lengthen difference. Although a window screen is attached to this entrance sliding door, the window screen is having the graphic display omitted in drawing 1.

0009Drawing 2 is a figure showing the cross section of the whole entrance sliding door, and drawing 3 is a figure showing the section of Kamoi 2 and the threshold 3. The reference marks 8 and 9 are the stiles which constitute the shoji 6, and the reference marks 10 and 11 are stiles which constitute the shoji 7. It is formed so that the guide rails 12 and 13 may project vertically, respectively as a member to which it shows opening and closing of the shoji 6 and the shoji 7, and the shojis 6 and 7 move to the upper surface of the threshold 3, sliding along

with the guide-rails 12 and 13. In the guide rails 12 and 13, the extension rails 12a and 13a are prolonged in parallel, respectively. On the other hand, in Kamoi 2, as shown in drawing 3, the guide rails 18 and 19 have hung vertically. The window screen 12 is arranged most in parallel with the shojis 6 and 7 at the outdoor side, can be slid along with the rail 17, and can be opened and closed.

0010Next, drawing 4 shows the A-A section of drawing 3, and shows the rebate 20 currently formed in the right longitudinal frame 5, and the rebate 22 of the left-vertical frame 4. First, the outer edge section of the stile 8 is the door end 8a, and the rebate 20 constitutes the crevice in which the door end 8a is accepted from the shoji 6, when the shoji 6 is shut. In this case, the width of the rebate 22 is set as the width dimension equivalent to one sheet of the shoji 6. As a result of forming a crevice like the rebate 20 in the right longitudinal frame 5, the step 23a is formed in the outdoor side in the right longitudinal frame 5. The airtight material 25 which the door end 8a of the shoji 6 at the time of full close approaches, and carries out the seal of the crevice between the door ends 8a to this step 23b is attached to the step 23b of another side by the side of the interior of a room which confronts this step 23a and rebate 20 each other in between.

0011On the other hand, in drawing 4, the rebate 22 is similarly formed in the left-vertical frame 4. The rebate 22 provided in this left-vertical frame 4 differs in width in the rebate 20 of the right longitudinal frame 5. It is constituted as a crevice which has the width for two sheets of the shojis 6 and 7, and the door end 11a which is an outer edge section of the stile 11 of the shoji 7 enters into the position which approached the interior-of-a-room side in the rebate 22. Thus, the step 23a of said right longitudinal frame 5 and the step 24a which counters are formed in the direction of an outdoor side by establishing the crevice which has the width for two sheets of the shojis 6 and 7 as the rebate 22 in the direction of the left-vertical frame 4. The airtight material 26 which the door end 11a of the shoji 7 at the time of full close approaches, and carries out the seal of the crevice between the door ends 11a of the shoji 7 to this step 24b is attached to the step 24b of another side by the side of the interior of a room which confronts this step 24a and rebate 22 each other in between.

0012As shown in drawing 2, the shielding member 30 which consists of a flexible material of rubber etc. is attached to the door ends 15a and 16a of the right and left of the window screen 14. This shielding member 30 is continued and prolonged for the overall length of the corner edge by the side of the interior of a room of 15a and 16a of a door end, and the fillet part 31 projects it toward the rebates 20 and 22.

0013In drawing 3 and drawing 4, the upper bed part of the stile 8 of the shoji 6 and the stile 11 of the shoji 7 is equipped with the rail swallowing member 30 which swallows the guide rails 18 and 19, respectively. This rail swallowing member 30 is a member of the cap form fitted in and attached to the upper bed part of the stiles 7 and 8 by the member made of long direction bodily-shape-like resin. As shown in drawing 4, the rail groove 31 which swallows the guide rails 18 and 19 is formed of the walls 32a and 32b, and the interval of the walls 32a and 32b has a size which took predetermined play in addition to the width of the guide rails 18 and 19 in this case.

0014Next, drawing 5 shows the spacing member 40 attached to the upper bed part of the left-vertical frame 4. As shown in drawing 5, when Kamoi 2 is joined to the left-vertical frame 4, in the upper bed part of the left-vertical frame 4, between Kamoi 2, a part of rebate 22 serves as an unnecessary space, and it will be left behind. the spacing member 40 is a member attached in order to fill this unnecessary space -- the width of the rebate 22, and abbreviation -- it has equal width and the height for an unnecessary space.

0015In drawing 4 and drawing 5, the rail extension members 41 and 42 which follow the guide rails 18 and 19 of Kamoi 2 are formed in such a spacing member 40, and integral moulding is carried out to it so that it may hang from the body part of the spacing member 40.

0016As shown in drawing 4, if the rail extension member 42 makes the shoji 7 full close and it is put into the rebate 22, it will be inserted in the rail groove 31 by a relation with the rail swallowing member 30 with which the stile 11 of the shoji 7 was equipped. and while the taper surface 42a is formed in this rail extension member 42 and this tapered surface 42a touches the inner surface of the wall 32b, the door end 11a of the shoji 7 is positioned in a proper position to the airtight member 26 -- it draws near and functions as a field.

0017The same spacing member 44 is attached also to the upper bed part of the right longitudinal frame 5. Since the width of the rebate 20 is one sheet of the shoji 6 in the case of the right longitudinal frame 5, the width of the spacing member 44 is equivalent to the width of the narrow rebate 20, and the rail extension member 46 which follows the guide rail 15 is

formed in one one. This rail extension member 46 is formed by the taper surface 46a by **who mentioned above / the rail extension member 42 and Hitoshi** , and this taper surface 46a, The point of positioning the door end 8a of the shoji 6 in a proper position to the airtight member 25 and of drawing near and functioning as a field is the same, touching the inner surface of the wall 32b of the rail swallowing member 30.

0018Next, drawing 6 is a figure showing the door end 11a just before making the shoji 7 into full close, and the physical relationship of the rail extension member 42. When moving in order to shut the shoji 7 since the floor roller which has been attached to the shoji 7 and which is not illustrated rolls in the case of the guide rail 18 of Kamoi 2, shakiness and blur of some arise. For this reason, a position just before the door end 11a of the shoji 7 enters into the rebate 22 assumes that the interior-of-a-room side was approached like drawing 6. If the shoji 7 is shut further and it puts into the rebate 22, the tapered surface 42a of the rail extension member 42 hits inside the wall 32b of the rail swallowing member 30, and the door end 11a can be drawn little by little near to the outdoor side according to the tapered surface 42a in the process in which the shoji 7 is shut thoroughly. Eventually, the door end 11a and the airtight member 26 are positioned by the position which touches properly.

0019Thus, by forming the rail extension member 42 in the spacer 40 at one, and establishing the tapered surface 42a in the rail extension member 42 further, even if blur arises in the shoji 7, it can draw near to the proper position in the rebate 22, and can position. Like this embodiment, since the rail extension member 42 can be hidden so that it may insert in a door end and may not be visible from outside if the shoji 7 is shut when the rebate 22 is broad with two shojis, the fine sight on a design especially improves. In order to hit the outside of the door end 11a of the shoji 7 at the broad rebate 22, not to provide the member which draws near and carries out the door end 11a, to reduce part mark and to fill the space which does not need a joining section with Kamoi 2, it can draw near to a certain spacer 40 from the former, and structure can be made to make it serve a double purpose.

0020Also when putting the door end 8a of the shoji 6 into the rebate 20 of the right longitudinal frame 5 in drawing 4, Similarly the wall 32b of the rail swallowing member 30 hits the spacer 44 in the tapered surface 46a of the really formed rail extension member 46, and the door end 8a of the shoji 6 can be drawn near to a proper position to the airtight material 25.

0021Drawing 7 shows the B-B section of drawing 3, and shows the spacing member 50 attached to the lower end part of the left-vertical frame 4. The positioning part 52 is formed in the spacing member 50 which fills the unnecessary space of the rebate 22 made at a left-vertical frame and the joining section of Kamoi 2 in one.

0022As shown in drawing 3 and drawing 7, the lower end part of the stile of the shoji 7 is also equipped with the same rail swallowing member 54. In this rail swallowing member 54, the crevice 55 of the section U type which *****s to the guide rail 12 is formed. The extension rail 12a hits the wall 56 formed in the rail swallowing member 54. Although the lower end part of the stile 8 of the shoji 6 of another side is also equipped with the rail swallowing member 34, a graphic display omits it.

0023In the case of the guide rail 12 of the threshold 3, the shoji 7 moves sliding and there are little shakiness and blur compared with the Kamoi 2 side. For this reason, since the wall 56 hits the side of the positioning member 52 just before being able to shut the shoji 7 and carrying out full close, applying the extension rail 12a to the wall 56 of the rail swallowing member 54, the door end 11a can be positioned in a proper position.

0024

Effect of the InventionAccording to this invention, the swallowing member of a shoji guiding rail is provided in the door-end side of a shoji so that clearly from the above explanation, The rail extension member which follows the shoji guiding rail of said cope box or a drag flask is formed in said spacing member in one, the door end of a shoji is positioned in a proper position to said airtight member, touching said rail extension member with the inner surface of said swallowing part, since it drew near and the field was formed, Since it can hide so that it may become possible to position the door end of a shoji in a suitable position to an airtight material, and a rail extension member may be inserted in a door end and it may not be visible from outside when making a shoji into full close, the fine sight on a design can be raised.

Field of the InventionThis invention relates to the opening device made as **position / the**

door end of a sliding door / by the proper position in a rebate , when the opening device which has a sliding door attached to the opening of houses, such as the door, is started and a sliding door is shut especially.

Description of the Prior ArtConventionally, this kind of opening device is widely used as an entrance sliding door in a common house. A sliding door consists of a shoji (door object) of two sheets opened and closed by lengthen difference, and a window screen is attached further in many cases.

0003In such a sliding door, the guide rail which shows a cope box or a drag flask to the opening and closing movement of a shoji can be provided, and can be, and it can open now to a shoji and close smoothly by making it fixed backlash and deflection arise.

0004The crevice called the rebate which accepts the door end of a shoji is formed in the door post, if a shoji is shut, the door end will go into a rebate, it will hit with an airtight material, and a crevice will arise.

Effect of the InventionAccording to this invention, the swallowing member of a shoji guiding rail is provided in the door-end side of a shoji so that clearly from the above explanation, The rail extension member which follows the shoji guiding rail of said cope box or a drag flask is formed in said spacing member in one, the door end of a shoji is positioned in a proper position to said airtight member, touching said rail extension member with the inner surface of said swallowing part, since it drew near and the field was formed, Since it can hide so that it may become possible to position the door end of a shoji in a suitable position to an airtight material, and a rail extension member may be inserted in a door end and it may not be visible from outside when making a shoji into full close, the fine sight on a design can be raised.

Problem(s) to be Solved by the InventionHowever, if it was in the drag flask, since it did not show around with a guide rail, when the door end of a shoji had shut the shoji thoroughly, the door end swayed and it had the fault that did not enter into a rebate or a crevice was made without a door end and an airtight material hitting properly.

0006Then, there is the purpose of this invention in providing the opening device which can position the door end of a shoji in a suitable position to an airtight material, when canceling the problem which said conventional technology has and making a shoji into full close.

0007

Means for Solving the ProblemA frame in which this invention was formed with a four-directions frame in order to attain the aforementioned purpose, While forming a rebate which consists of a crevice which is an opening device which has a shoji of two right and left opened and closed by lengthen difference within said frame, and accepts a door end of a shoji in a door post of said right and left, respectively, An airtight material is formed in a door end of a shoji at the time of full close, a step of an approaching rebate, or said door end, a spacing member for filling an unnecessary space of a rebate formed in a joining section with said vertical frame is attached to at least one end of said door post -- both, Provide a swallowing part of a shoji guiding rail in the door-end side of said shoji, and to said spacing member. It is characterized by a thing which position a door end of a shoji in a proper position to said airtight member and for which it drew near and a part was formed, forming in one a rail extension member extended from a shoji guiding rail of said cope box or a drag flask, and touching said rail extension member with an inner surface of said swallowing part.

0008

Embodiment of the InventionHereafter, one embodiment of the opening device by this invention is described, referring to attached Drawings. Drawing 1 is a front view showing the embodiment which applied this invention to the entrance sliding door of the house. Kamoi 2 which is a cope box, the threshold 3 which is drag flasks, and the frame which carried out the

four-quarters group of the door posts 4 and 5 on either side are attached to the opening of the door, and it is built so that the shojis 6 and 7 of two sheets may be opened and closed by this frame at a lengthen difference. Although a window screen is attached to this entrance sliding door, the window screen is having the graphic display omitted in drawing 1.

0009Drawing 2 is a figure showing the cross section of the whole entrance sliding door, and drawing 3 is a figure showing the section of Kamoi 2 and the threshold 3. The reference marks 8 and 9 are the stiles which constitute the shoji 6, and the reference marks 10 and 11 are stiles which constitute the shoji 7. It is formed so that the guide rails 12 and 13 may project vertically, respectively as a member to which it shows opening and closing of the shoji 6 and the shoji 7, and the shojis 6 and 7 move to the upper surface of the threshold 3, sliding along with the guide rails 12 and 13. In the guide rails 12 and 13, the extension rails 12a and 13a are prolonged in parallel, respectively. On the other hand, in Kamoi 2, as shown in drawing 3, the guide rails 18 and 19 have hung vertically. The window screen 12 is arranged most in parallel with the shojis 6 and 7 at the outdoor side, can be slid along with the rail 17, and can be opened and closed.

0010Next, drawing 4 shows the A-A section of drawing 3, and shows the rebate 20 currently formed in the right longitudinal frame 5, and the rebate 22 of the left-vertical frame 4. First, the outer edge section of the stile 8 is the door end 8a, and the rebate 20 constitutes the crevice in which the door end 8a is accepted from the shoji 6, when the shoji 6 is shut. In this case, the width of the rebate 22 is set as the width dimension equivalent to one sheet of the shoji 6. As a result of forming a crevice like the rebate 20 in the right longitudinal frame 5, the step 23a is formed in the outdoor side in the right longitudinal frame 5. The airtight material 25 which the door end 8a of the shoji 6 at the time of full close approaches, and carries out the seal of the crevice between the door ends 8a to this step 23b is attached to the step 23b of another side by the side of the interior of a room which confronts this step 23a and rebate 20 each other in between.

0011On the other hand, in drawing 4, the rebate 22 is similarly formed in the left-vertical frame 4. The rebate 22 provided in this left-vertical frame 4 differs in width in the rebate 20 of the right longitudinal frame 5, It is constituted as a crevice which has the width for two sheets of the shojis 6 and 7, and the door end 11a which is an outer edge section of the stile 11 of the shoji 7 enters into the position which approached the interior-of-a-room side in the rebate 22. Thus, the step 23a of said right longitudinal frame 5 and the step 24a which counters are formed in the direction of an outdoor side by establishing the crevice which has the width for two sheets of the shojis 6 and 7 as the rebate 22 in the direction of the left-vertical frame 4. The airtight material 26 which the door end 11a of the shoji 7 at the time of full close approaches, and carries out the seal of the crevice between the door ends 11a of the shoji 7 to this step 24b is attached to the step 24b of another side by the side of the interior of a room which confronts this step 24a and rebate 22 each other in between.

0012As shown in drawing 2, the shielding member 30 which consists of a flexible material of rubber etc. is attached to the door ends 15a and 16a of the right and left of the window screen 14. This shielding member 30 is continued and prolonged for the overall length of the corner edge by the side of the interior of a room of 15a and 16a of a door end, and the fillet part 31 projects it toward the rebates 20 and 22.

0013In drawing 3 and drawing 4, the upper bed part of the stile 8 of the shoji 6 and the stile 11 of the shoji 7 is equipped with the rail swallowing member 30 which swallows the guide rails 18 and 19, respectively. This rail swallowing member 30 is a member of the cap form fitted in and attached to the upper bed part of the stiles 7 and 8 by the member made of long direction bodily-shape-like resin. As shown in drawing 4, the rail groove 31 which swallows the guide rails 18 and 19 is formed of the walls 32a and 32b, and the interval of the walls 32a and 32b has a size which took predetermined play in addition to the width of the guide rails 18 and 19 in this case.

0014Next, drawing 5 shows the spacing member 40 attached to the upper bed part of the left-vertical frame 4. As shown in drawing 5, when Kamoi 2 is joined to the left-vertical frame 4, in the upper bed part of the left-vertical frame 4, between Kamoi 2, a part of rebate 22 serves as an unnecessary space, and it will be left behind. the spacing member 40 is a member attached in order to fill this unnecessary space -- the width of the rebate 22, and abbreviation -- it has equal width and the height for an unnecessary space.

0015In drawing 4 and drawing 5, the rail extension members 41 and 42 which follow the guide rails 18 and 19 of Kamoi 2 are formed in such a spacing member 40, and integral moulding is carried out to it so that it may hang from the body part of the spacing member 40.

0016As shown in drawing 4, if the rail extension member 42 makes the shoji 7 full close and it is put into the rebate 22, it will be inserted in the rail groove 31 by a relation with the rail swallowing member 30 with which the stile 11 of the shoji 7 was equipped. and while the taper surface 42a is formed in this rail extension member 42 and this tapered surface 42a touches the inner surface of the wall 32b, the door end 11a of the shoji 7 is positioned in a proper position to the airtight member 26 -- it draws near and functions as a field.

0017The same spacing member 44 is attached also to the upper bed part of the right longitudinal frame 5. Since the width of the rebate 20 is one sheet of the shoji 6 in the case of the right longitudinal frame 5, the width of the spacing member 44 is equivalent to the width of the narrow rebate 20, and the rail extension member 46 which follows the guide rail 15 is formed in one one. This rail extension member 46 is formed by the taper surface 46a by **who mentioned above / the rail extension member 42 and Hitoshi** , and this taper surface 46a, The point of positioning the door end 8a of the shoji 6 in a proper position to the airtight member 25 and of drawing near and functioning as a field is the same, touching the inner surface of the wall 32b of the rail swallowing member 30.

0018Next, drawing 6 is a figure showing the door end 11a just before making the shoji 7 into full close, and the physical relationship of the rail extension member 42. When moving in order to shut the shoji 7 since the floor roller which has been attached to the shoji 7 and which is not illustrated rolls in the case of the guide rail 18 of Kamoi 2, shakiness and blur of some arise. For this reason, a position just before the door end 11a of the shoji 7 enters into the rebate 22 assumes that the interior-of-a-room side was approached like drawing 6. If the shoji 7 is shut further and it puts into the rebate 22, the tapered surface 42a of the rail extension member 42 hits inside the wall 32b of the rail swallowing member 30, and the door end 11a can be drawn little by little near to the outdoor side according to the tapered surface 42a in the process in which the shoji 7 is shut thoroughly. Eventually, the door end 11a and the airtight member 26 are positioned by the position which touches properly.

0019Thus, by forming the rail extension member 42 in the spacer 40 at one, and establishing the tapered surface 42a in the rail extension member 42 further, even if blur arises in the shoji 7, it can draw near to the proper position in the rebate 22, and can position. Like this embodiment, since the rail extension member 42 can be hidden so that it may insert in a door end and may not be visible from outside if the shoji 7 is shut when the rebate 22 is broad with two shojis, the fine sight on a design especially improves. In order to hit the outside of the door end 11a of the shoji 7 at the broad rebate 22, not to provide the member which draws near and carries out the door end 11a, to reduce part mark and to fill the space which does not need a joining section with Kamoi 2, it can draw near to a certain spacer 40 from the former, and structure can be made to make it serve a double purpose.

0020Also when putting the door end 8a of the shoji 6 into the rebate 20 of the right longitudinal frame 5 in drawing 4, Similarly the wall 32b of the rail swallowing member 30 hits the spacer 44 in the tapered surface 46a of the really formed rail extension member 46, and the door end 8a of the shoji 6 can be drawn near to a proper position to the airtight material 25.

0021Drawing 7 shows the B-B section of drawing 3, and shows the spacing member 50 attached to the lower end part of the left-vertical frame 4. The positioning part 52 is formed in the spacing member 50 which fills the unnecessary space of the rebate 22 made at a left-vertical frame and the joining section of Kamoi 2 in one.

0022As shown in drawing 3 and drawing 7, the lower end part of the stile of the shoji 7 is also equipped with the same rail swallowing member 54. In this rail swallowing member 54, the crevice 55 of the section U type which ****s to the guide rail 12 is formed. The extension rail 12a hits the wall 56 formed in the rail swallowing member 54. Although the lower end part of the stile 8 of the shoji 6 of another side is also equipped with the rail swallowing member 34, a graphic display omits it.

0023In the case of the guide rail 12 of the threshold 3, the shoji 7 moves sliding and there are little shakiness and blur compared with the Kamoi 2 side. For this reason, since the wall 56 hits the side of the positioning member 52 just before being able to shut the shoji 7 and carrying out full close, applying the extension rail 12a to the wall 56 of the rail swallowing member 54, the door end 11a can be positioned in a proper position.

Brief Description of the Drawings

Drawing 1The front view showing one embodiment which applied the opening device by this invention to the entrance sliding door.

Drawing 2The cross-sectional view of the entrance sliding door by the embodiment.

Drawing 3The figure showing the section of Kamoi of an entrance sliding door, and a threshold.

Drawing 4The figure in which showing the A-A section in drawing 3, and showing the physical relationship in the state where the door end of the shoji was put into the rebate provided in the right-and-left door post.

Drawing 5The perspective view showing the spacing member attached to the upper bed part of a left-vertical frame.

Drawing 6The figure showing an operation of the rail extension member provided in the spacing member in one.

Drawing 7The figure in which showing the B-B section in drawing 3, and showing the spacing member attached to the lower end part of a left-vertical frame, and the rail swallowing member with which the door end of the shoji was equipped.

Description of Notations

2 Kamoi

3 Threshold

4 Left-vertical frame

5 Right longitudinal frame

6 Shoji

7 Shoji

12 Window screen

20 Rebate

22 Rebate

23a and 23b Step

24a and 24b Step

25 Airtight material

26 Airtight material

30 Rail swallowing member

40 Spacing member

42 Rail extension member

42a Tapered surface

Drawing 2

For drawings please refer to the original document.

Drawing 1

For drawings please refer to the original document.

Drawing 3

For drawings please refer to the original document.

Drawing 4

For drawings please refer to the original document.

Drawing 5

For drawings please refer to the original document.

Drawing 6

For drawings please refer to the original document.

Drawing 7

For drawings please refer to the original document.

For drawings please refer to the original document.

(19) 日本国特許庁 (JP)

(12) 公開特許公報 (A)

(11) 特許出願公開番号

特開2003-56254

(P2003-56254A)

(43) 公開日 平成15年2月26日 (2003.2.26)

(51) Int.Cl. ⁷	識別記号	F I	テーマコード(参考)
E 0 6 B	3/46	E 0 6 B	2 E 0 1 4
	7/22		Z 2 E 0 3 6

審査請求 未請求 請求項の数 1 OL (全 6 頁)

(21) 出願番号 特願2001-244149(P2001-244149)
 (22) 出願日 平成13年8月10日 (2001.8.10)

(71) 出願人 302043705
 トステム株式会社
 東京都江東区大島2丁目1番1号
 (72) 発明者 野上 剛
 東京都江東区大島2丁目1番1号 トステ
 ム株式会社内
 (74) 代理人 10007/687
 弁理士 後藤田 章
 Fターム(参考) 2E014 AA01 FA06 FB01 FB06 FB11
 2E036 AA02 BA01 CA01 DA02 EB07
 GA02 HB05 HC03 HC07

(54) 【発明の名称】 開口部装置

(57) 【要約】

【課題】 障子を全閉にするときに障子の戸先を気密材に対して適切な位置に位置決めする。

【解決手段】 左右の縦枠4、5にそれぞれ障子の戸先を受け入れる凹部からなる戸じゃくり20、22を形成するとともに、全閉時の障子の戸先に近接する戸じゃくりの段部23b、24bに気密材25、26を設け、上下枠2、3との接合部分に形成される戸じゃくり22の不要なスペースを埋めるためのスペーサ部材40、44を前記縦枠の少なくとも一方の端部に取り付けるとともに、前記障子の戸先側に障子案内レール13の呑み込み部材30を設け、スペーサ部材40に、障子案内レール13から延長されるレール延長部材42、46を一体的に形成し、このレール延長部材42に呑み込み部材30の内面と接しながら障子の戸先を気密部材25、26に対して適正な位置に位置決めする引き寄せ面42a、46aを形成する。

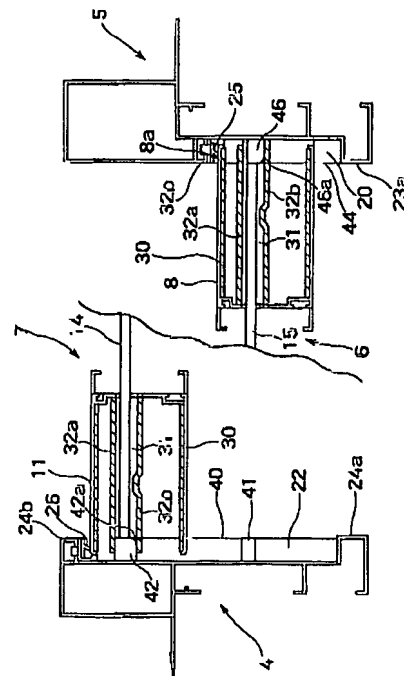

【特許請求の範囲】

【請求項1】上下左右枠により形成された枠体と、前記枠体内で引き違いに開閉される左右2枚の障子と、を有する開口部装置であって、前記左右の縦枠にそれぞれ障子の戸先を受け入れる凹部からなる戸じゃくりを形成するとともに、全閉時の障子の戸先と近接する戸じゃくりの段部または前記戸先に気密材を設け、前記上下枠との接合部分に形成される戸じゃくりの不要なスペースを埋めるためのスペーサ部材を前記縦枠の少なくとも一方の端部に取り付けるとともに、前記障子の戸先側に障子案内レールの呑み込み部を設け、前記スペーサ部材に、前記上枠または下枠の障子案内レールから延長されるレール延長部材を一体的に形成し、前記レール延長部材に前記呑み込み部の内面と接しながら障子の戸先を前記気密部材に対して適正な位置に位置決めする引き寄せ部を形成したことを特徴とする開口部装置。

【発明の詳細な説明】

【0001】

【発明の属する技術分野】本発明は、玄関等の家屋の開口部に取り付けられる引き戸を有する開口部装置に係り、特に、引き戸を閉めたときに、引き戸の戸先が戸じゃくり内の適正な位置に位置決めされるようになった開口部装置に関する。

【0002】

【従来の技術】従来、この種の開口部装置は、一般家屋における玄関引き戸として広く利用されている。引き戸は、引き違いに開閉される2枚の障子（戸体）からなり、さらに網戸が取り付けられることが多い。

【0003】このような引き戸においては、上枠または下枠に障子の開閉移動を案内するガイドレールが設けられ、障子には一定のガタつきや振れが生じるようにすることで、スムーズに開け閉めすることができるようになっている。

【0004】また、縦枠には、障子の戸先を受け入れる戸じゃくりと呼ばれる凹部が形成されており、障子を閉めると、その戸先が戸じゃくりに入って気密材と当たり、隙間が生じないようにしている。

【0005】

【発明が解決しようとする課題】しかしながら、下枠にあっては障子の戸先までは、ガイドレールによって案内されないために、障子を完全に閉めるときに、戸先が振れて戸じゃくりに入り込まなかったり、戸先と気密材が適正に当たらずに隙間ができるという欠点があった。

【0006】そこで、本発明の目的は、前記従来技術の有する問題点を解消し、障子を全閉にするときに障子の戸先を気密材に対して適切な位置に位置決めすることが可能な開口部装置を提供することにある。

【0007】

【課題を解決するための手段】前記の目的を達成するために、本発明は、上下左右枠により形成された枠体と、前記枠体内で引き違いに開閉される左右2枚の障子と、を有する開口部装置であって、前記左右の縦枠にそれぞれ障子の戸先を受け入れる凹部からなる戸じゃくりを形成するとともに、全閉時の障子の戸先と近接する戸じゃくりの段部または前記戸先に気密材を設け、前記上下枠との接合部分に形成される戸じゃくりの不要なスペースを埋めるためのスペーサ部材を前記縦枠の少なくとも一方の端部に取り付けるとともに、前記障子の戸先側に障子案内レールの呑み込み部を設け、前記スペーサ部材に、前記上枠または下枠の障子案内レールから延長されるレール延長部材を一体的に形成し、前記レール延長部材に前記呑み込み部の内面と接しながら障子の戸先を前記気密部材に対して適正な位置に位置決めする引き寄せ部を形成したことを特徴とするものである。

【0008】

【発明の実施の形態】以下、本発明による開口部装置の一実施形態について、添付の図面を参照しながら説明する。図1は、本発明を家屋の玄関引き戸に適用した実施形態を示す正面図である。玄関の開口部には、上枠である鴨居2、下枠である敷居3、左右の縦枠4、5を四方組した枠体に取り付けられており、この枠体に2枚の障子6、7が引き違いに開閉されるように建て付けられている。この玄関引き戸には、網戸が取り付けられるようになっているが、図1では網戸は図示を省略されている。

【0009】図2は、玄関引き戸全体の横断面を示す図で、図3は鴨居2、敷居3の断面を示す図である。参照符号8、9は、障子6を構成する縦框で、参照符号10、11は障子7を構成する縦框である。敷居3の上には、障子6、障子7の開閉を案内する部材としてそれぞれガイドレール12、13が垂直に突き出るように形成されており、障子6、7は、ガイドレール12、13に沿って摺動しながら移動する。また、ガイドレール12、13には、それぞれ補助レール12a、13aが平行に延びようになっている。一方、鴨居2には、図3に示されるように、ガイドレール18、19が垂直に垂下している。なお網戸12は、障子6、7と平行に最も室外側に配置されており、レール17に沿って滑动させて開け閉めすることができる。

【0010】次に、図4は、図3のA-A断面を示し、右縦枠5に形成されている戸じゃくり20と、左縦枠4の戸じゃくり22を示している。まず、障子6では、縦框8の外縁部が戸先8aになっており、戸じゃくり20は、障子6を閉めたときに、戸先8aを受け入れる凹部を構成している。この場合、戸じゃくり22の幅は、障子6の一枚分に相当する幅寸法に設定されている。また、戸じゃくり20のような凹部を右縦枠5に形成した結果、右縦枠5においては、室外側に段部23aが形成

されている。この段部23aと戸ジャクリ20を間に対峙する室内側の他方の段部23bには、全閉時の障子6の戸先8aが近接するようになっており、この段部23bには戸先8aとの間の隙間をシールする気密材25が取り付けられている。

【0011】他方、図4において、左縦枠4においても、同様に戸ジャクリ22が形成されている。この左縦枠4に設けた戸ジャクリ22は、右縦枠5の戸ジャクリ20とは幅が異なっており、障子6、7の2枚分の幅を有する凹部として構成されており、障子7の縦框11の外縁部である戸先11aは、戸ジャクリ22において室内側に寄った位置に入り込むようになっている。このように、左縦枠4の方に障子6、7の2枚分の幅を有する凹部を戸ジャクリ22として設けることによって、室外側の方に前記右縦枠5の段部23aと対向する段部24aが形成されている。この段部24aと戸ジャクリ22を間に対峙する室内側の他方の段部24bには、全閉時の障子7の戸先11aが近接するようになっており、この段部24bには、障子7の戸先11aとの間の隙間をシールする気密材26が取り付けられている。

【0012】なお、図2に示されるように、網戸14の左右の戸先15a、16aには、ゴム等の可撓性の材料からなる遮蔽部材30が取り付けられている。この遮蔽部材30は、戸先の15a、16aの室内側のコーナ縁の全長に亘って延びており、ヒレ部31が戸ジャクリ20、22に向かって張り出すようになっている。

【0013】図3、図4において、障子6の縦框8、障子7の縦框11の上端部には、それぞれガイドレール18、19を呑み込むレール呑込み部材30が装着されている。このレール呑込み部材30は、長方形形状の樹脂製の部材で縦框7、8の上端部に嵌装して取り付けるキャップ形式の部材である。図4に示すように、ガイドレール18、19を呑み込むレール溝31が壁部32a、32bによって形成され、この場合、壁部32a、32bの間隔は、ガイドレール18、19の幅に加えて所定の遊びをとった寸法になっている。

【0014】次に、図5は、左縦枠4の上端部に取り付けられるスペーサ部材40を示す。図5に示されるように、左縦枠4に鴨居2を接合すると、左縦枠4の上端部では戸ジャクリ22の一部分が鴨居2との間に不要なスペースとなって残されることになる。スペーサ部材40は、この不要なスペースを埋めるために取り付けられる部材で、戸ジャクリ22の幅と略等しい幅と、不要なスペース分の高さを有している。

【0015】図4および図5において、このようなスペーサ部材40には、鴨居2のガイドレール18、19に連続するレール延長部材41、42が設けられており、スペーサ部材40の本体部から垂下するように一体形成されている。

【0016】図4に示すように、レール延長部材42

は、障子7の縦框11に装着されたレール呑込み部材30との関係では、障子7を全閉にして戸ジャクリ22に入ると、レール溝31に嵌入するようになっている。そして、このレール延長部材42には、テーパ面42aが形成されており、このテーパ面42aは、壁部32bの内面に接しながら、障子7の戸先11aを気密部材26に対して適正な位置に位置決めする引き寄せ面として機能するようになっている。

【0017】右縦枠5の上端部にも、同様のスペーサ部材44が取り付けられている。右縦枠5の場合、戸ジャクリ20の幅は、障子6の一枚分であるため、スペーサ部材44の幅は、その狭い戸ジャクリ20の幅に対応し、ガイドレール15に連続するレール延長部材46が1つ一体に形成されている。このレール延長部材46は、前述したレール延長部材42と同様にテーパ面46aが形成され、このテーパ面46aは、レール呑込み部材30の壁部32bの内面に接しながら、障子6の戸先8aを気密部材25に対して適正な位置に位置決めする引き寄せ面として機能するようになっている点は同様である。

【0018】次に、図6は、障子7を全閉にする直前の戸先11aと、レール延長部材42の位置関係を示す図である。鴨居2のガイドレール18の場合、障子7に取り付けてある図示しない戸車が転動するので、障子7を閉めるために移動する際には、多少のがたつきやぶれが生じる。このため、障子7の戸先11aが戸ジャクリ22に入り込む直前の位置が図6のように室内側に寄っていたとする。障子7をさらに閉めて、戸ジャクリ22に入ると、レール呑込み部材30の壁部32bの内側にレール延長部材42のテーパ面42aが当たり、完全に障子7を閉める過程で、テーパ面42aによって戸先11aは、室外側に少しずつ引き寄せられる。最終的には、戸先11aと気密部材26が適正に接する位置に位置決めされる。

【0019】このように、スペーサ40にレール延長部材42を一体に設け、さらにレール延長部材42にテーパ面42aを設けることで、障子7にぶれが生じても戸ジャクリ22内の適正な位置に引き寄せて位置決めすることができる。とりわけ、本実施形態のように、戸ジャクリ22が障子2枚分と幅広になっている場合、障子7を閉めると、レール延長部材42は戸先に嵌入して外から見えないように隠せるので、意匠上の美観が向上する。また、幅広の戸ジャクリ22に障子7の戸先11aの外側に当たって戸先11aを引き寄せする部材を設ける必要がなく、部品点数を削減し鴨居2との接合部分の不要なスペースを埋めるために従来からあるスペーサ40に引き寄せ構造を兼用させることができる。

【0020】なお、図4において、右縦枠5の戸ジャクリ20に障子6の戸先8aを入れるときも、同様に、スペーサ44に一体形成したレール延長部材46のテーパ

面46aにレール呑込み部材30の壁部32bが当たって、障子6の戸先8aは気密材25に対して適正な位置に引き寄せられる。

【0021】図7は、図3のB-B断面を示し、左縦枠4の下端部に取り付けられるスペーサ部材50を示す。左縦枠と鴨居2の接合部分にできる戸じゃくり22の不要なスペースを埋めるスペーサ部材50には、位置決め部52が一体的に設けられている。

【0022】図3および図7に示されるように、同じようなレール呑込み部材54は、障子7の縦枠の下端部にも装着されている。このレール呑込み部材54では、ガイドレール12と摺接する断面U字形の凹部55が形成されている。また、補助レール12aは、レール呑込み部材54に形成された内壁56に当たるようになっている。なお、レール呑込み部材34は、他方の障子6の縦枠8の下端部にも装着されているが、図示は省略する。

【0023】敷居3のガイドレール12の場合、障子7は滑りながら移動し鴨居2側に比べてがたつきやぶれが少ない。このため、レール呑込み部材54の内壁56に補助レール12aを当てながら障子7を閉めることができ、全閉する直前には、位置決め部材52の側面に内壁56が当たるので、戸先11aを適正な位置に位置決めすることができる。

【0024】
【発明の効果】以上の説明から明らかなように、本発明によれば、障子の戸先側に障子案内レールの呑込み部材を設け、前記スペーサ部材に、前記上枠または下枠の障子案内レールに連続するレール延長部材を一体的に形成し、前記レール延長部材に前記呑込み部の内面と接しながら障子の戸先を前記気密部材に対して適正な位置に位置決めする引き寄せ面を形成したので、障子を全閉にするとときに障子の戸先を気密材に対して適切な位置に位置決めすることが可能となり、また、レール延長部材を戸先に嵌入して外から見えなように隠せるので、意

匠上の美観を向上させることができる。

【図面の簡単な説明】

【図1】本発明による開口部装置を玄関引き戸に適用した一実施形態を示す正面図。

【図2】同実施形態による玄関引き戸の横断面図。

【図3】玄関引き戸の鴨居と敷居の断面を示す図。

【図4】図3におけるA-A断面を示し、左右縦枠に設けた戸じゃくり障子の戸先を入れた状態の位置関係を示す図。

【図5】左縦枠の上端部に取り付けられるスペーサ部材を示す斜視図。

【図6】スペーサ部材に一体的に設けたレール延長部材の作用を示す図。

【図7】図3におけるB-B断面を示し、左縦枠の下端部に取り付けられるスペーサ部材と障子の戸先に装着したレール呑込み部材を示す図。

【符号の説明】

- 2 鴨居
- 3 敷居
- 4 左縦枠
- 5 右縦枠
- 6 障子
- 7 障子
- 12 網戸
- 20 戸じゃくり
- 22 戸じゃくり
- 23a、23b 段部
- 24a、24b 段部
- 25 気密材
- 26 気密材
- 30 レール呑込み部材
- 40 スペーサ部材
- 42 レール延長部材
- 42a テーパー面

【図2】

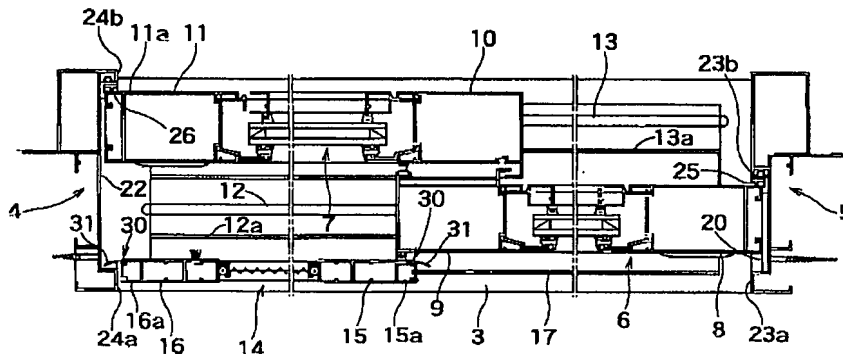

【図1】

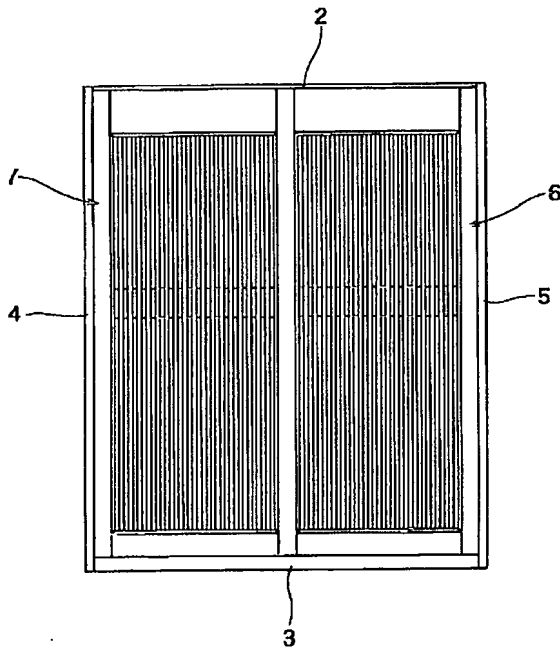

【図3】

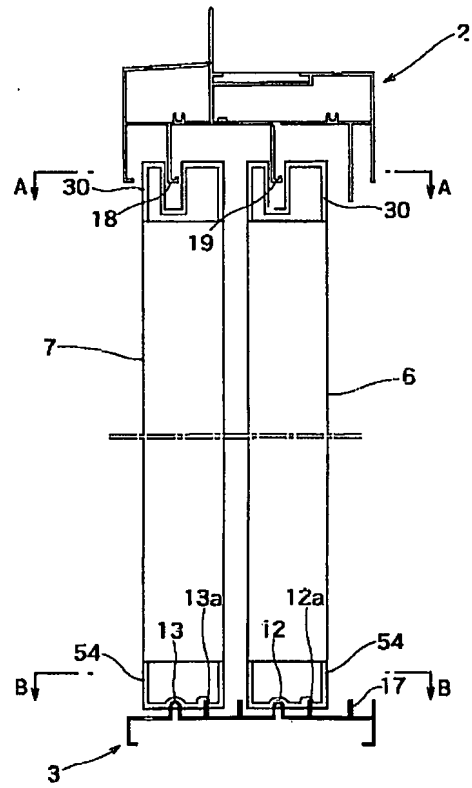

【図4】

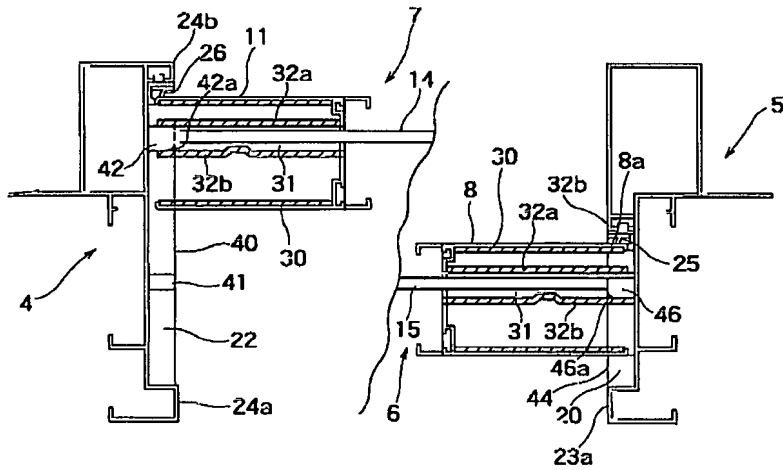

【圖5】

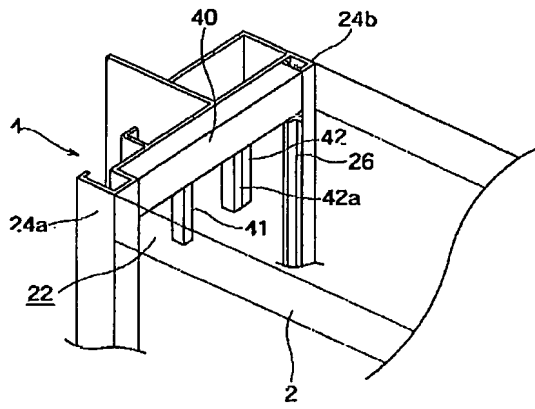

【圖6】

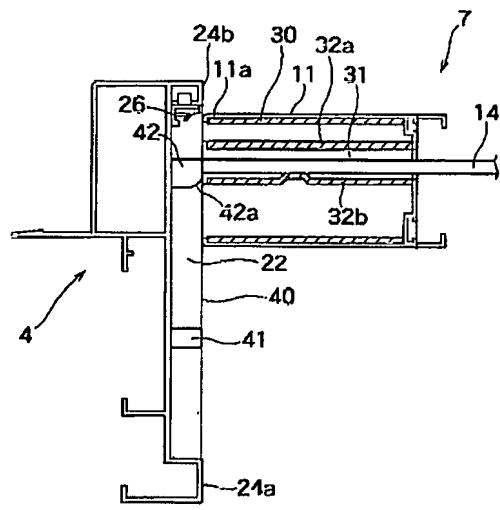

【圖7】

